

FlashForge Hunter 3D Printer User Guide



Content

Content.....	2
Introduction.....	5
Notice.....	6
Chapter 1: 3D Printing Technology.....	9
1.1 Process.....	9
Chapter 2 . About Hunter.....	11
2.1 About Your Hunter.....	11
Chapter 3. Unpacking.....	15
Chapter 4 . Hardware Assembly.....	20
4.1 Pour Photopolymer Resin in to Vat.....	20
4.2 Plug in Power Cable& turn on the Hunter.....	21
4.3 Screen.....	22
Chapter 5: About Software.....	28
5.1 Software Installation.....	28
5.2 Exploring FlashPrint.....	29
Chapter 6: Printing.....	48
6.1 Generate Gcode File.....	48
6.2 Methods of printing.....	50
6.3 Model Processing.....	51
Chapter 7: Supports and Service.....	53

Preface

On the completion of this User Guide, thanks all FlashForge engineers and the FlashForge 3D printer users for their unremitting efforts and sincere assistance.

The FlashForge Hunter User Guide is designed for the Hunter users to start their printing journey with FlashForge Hunter. Even if you are familiar with earlier FlashForge machines or 3D printing technology, we still recommend that you read through this guide, as there is lots of important information about the Hunter for you to get a better 3D experience.

For a better and more successful printing experience, you can refer to the following materials:

(1) Quick Start Guide

Users will find the Quick Start Guide together with the printer accessories. The Quick Start Guide will help you start your print journey as soon as possible.

(2) Official FlashForge Website: <http://www.FlashForge.com>

The official FlashForge website contains the up-to-date information concerning FlashForge software, firmware, device maintenance and so on. Users are also able to get the contact information from there.

FCC STATEMENT :

This device complies with Part 15 of the FCC Rules. Operation is subject to the following two conditions:

- (1) This device may not cause harmful interference,
- (2) This device must accept any interference received, including interference that may cause undesired operation.

Warning:

Changes or modifications not expressly approved by the party responsible for

compliance could void the user's authority to operate the equipment.

NOTE: This equipment has been tested and found to comply with the limits for a Class B digital device, pursuant to Part 15 of the FCC Rules. These limits are designed to provide reasonable protection against harmful interference in a residential installation. This equipment generates uses and can radiate radio frequency energy and, if not installed and used in accordance with the instructions, may cause harmful interference to radio communications. However, there is no guarantee that interference will not occur in a particular installation. If this equipment does cause harmful interference to radio or television reception, which can be determined by turning the equipment off and on, the user is encouraged to try to correct the interference by one or more of the following measures:

- Reorient or relocate the receiving antenna.

- Increase the separation between the equipment and receiver.

- Connect the equipment into an outlet on a circuit different from that to which the receiver is connected.

- Consult the dealer or an experienced radio/TV technician for help.

Introduction

Notes:

- Please read *FlashForge Hunter 3D Printer User Guide* carefully before use.
- The User Guide is written based on Windows 7 OS.
- The version of the FlashPrint is the latest.

The *FlashForge Hunter 3D Printer User Guide* contains the information needed for you to set up and use this device.

This User Guide includes the following parts: Preface, Introduction and After-sale service.

The Preface section includes resource acquisition channel, the overall framework of the manual, and the problems that should be paid attention to.

The introduction section contains the presentation of 3D printing technology, equipment introduction, unpacking and installation of equipment, software installation and usage.

After-sale section covers how to get the support and help.

Notice

Safety Notice

! Notices: Read all the instructions in the manual and familiarize yourself with the FlashForge Hunter User Guide before setting-up and using. Failure to comply with the warning and instructions may result in individual injury, fire, equipment damage or property damage.

PLEASE STRICTLY FOLLOW ALL THE SAFETY WARNINGS AND NOTICE BELOW ALL THE TIME.

- **Work Environment Safety**

- ① Keep your work place tidy.
- ② Do not operate Hunter in the presence of flammable liquids, gases or dust.
- ③ Hunter should be placed out of children and untrained people's reach.

- **Electricity Safety**

- ① Always use the Hunter with a properly grounded outlet. Do not refit Hunter plug.
- ② Do not use Hunter in damp or wet locations. Do not expose Hunter to burning sun.
- ③ Do not abuse the cable.
- ④ Avoid using the device during an thunderstorm.
- ⑤ In case of uncertain accident, please unplug the device if you do not use it for long.

- **Personal Safety**

- ① please don't direct touch the photopolymer resin with hands.
- ② Please put on gloves and masks during operation.
- ③ Please don't look at the light source directly.

④ Do not operate the device while you are tired or under the influence of drugs, alcohol or medication.

- **Cautions**

- ① Do not leave the device unattended for long.
- ② Do not make any modifications to the device.
- ③ Do not operate the device in bright light.
- ④ Operate the device in a well-ventilated environment.
- ⑤ Never use the device for illegal activities.
- ⑥ Never use the device to make any food storage vessels.
- ⑦ Never use the device to make any electrical appliance.
- ⑧ Never put the model into your mouth.
- ⑨ Do not remove the models with force.

- **Environment Requirements**

Temperature: RT 15-30°C

Moisture: 20%-70%

- **Photopolymer Resin Requirements**

Do not abuse the photopolymer resin. Please make sure you use the FlashForge photopolymer resin or the photopolymer resin from the brands accepted by FlashForge.

- **Photopolymer Resin Storage**

Unused photopolymer resin needs to be stored in a dark, dry, cool place, and out of the reach of children.

Legal Notice

All the information in this document is subject to any amendment or change without the official authorization from FlashForge.

FLASHFORGE CORPORATION MAKES NO WARRANTY OF ANY KIND WITH REGARD TO THIS DOCUMENT, INCLUDING, BUT NOT LIMITED TO, THE IMPLIED WARRANTIES OF MERCHANTABILITY AND FITNESS FOR A PARTICULAR PURPOSE.

FlashForge shall not be liable for errors contained herein for incidental consequential damages in connection with furnishing, performance or use of this material

This document contains proprietary information protected by copyright.
Copyright © 2017 FlashForge Corp. All Rights Reserved

Chapter 1: 3D Printing Technology

Digital Light Processing (DLP) is a new method of 3D printing. It is also the method that the Hunter uses. It works by first digitally processing the image signal, and then projecting the light to the photosensitive resin vat to get a solid model according to the irradiation projection.

1.1 Process

3D printing involves three steps:

- 1.) Make or download a 3D model
- 2.) Slice and export the 3D model
- 3.) Build the 3D model

1.1.1 Make a 3D Model

Currently, there are three ways of creating a 3D model.

- **Designing From Scratch** You can use free CAD (computer-aided design) software such as 3DTADA, AutoCAD, SolidWorks, Pro-E, and our own software Happy 3D to design your own 3D model.
- **3D Scanners** An alternative method to creating a 3D model is to scan an object. 3D scanners work by digitizing a physical object, collecting its geometric data, and saving it to a file on your PC. There are also apps that can turn a mobile device into a 3D scanner.
- **From the Cloud** The most popular way of obtaining a 3D model is to download it from websites that allow users to upload 3D models that they designed.

E.g. www.thingiverse.com

1.1.2 Slice and Export the 3D Model

Slice software is the software that prepares 3D models for printing and turns them into instructions for the 3D printers. FlashPrint is the slicing software used for the FlashForge Hunter.

Using FlashPrint, you can prepare files to be SVGX files for printing. Then the files can be transferred to your Hunter via USB cable, USB stick or Wi-Fi.

Chapter 2 . About Hunter

2.1 About Your Hunter

2.1.1 Main view:

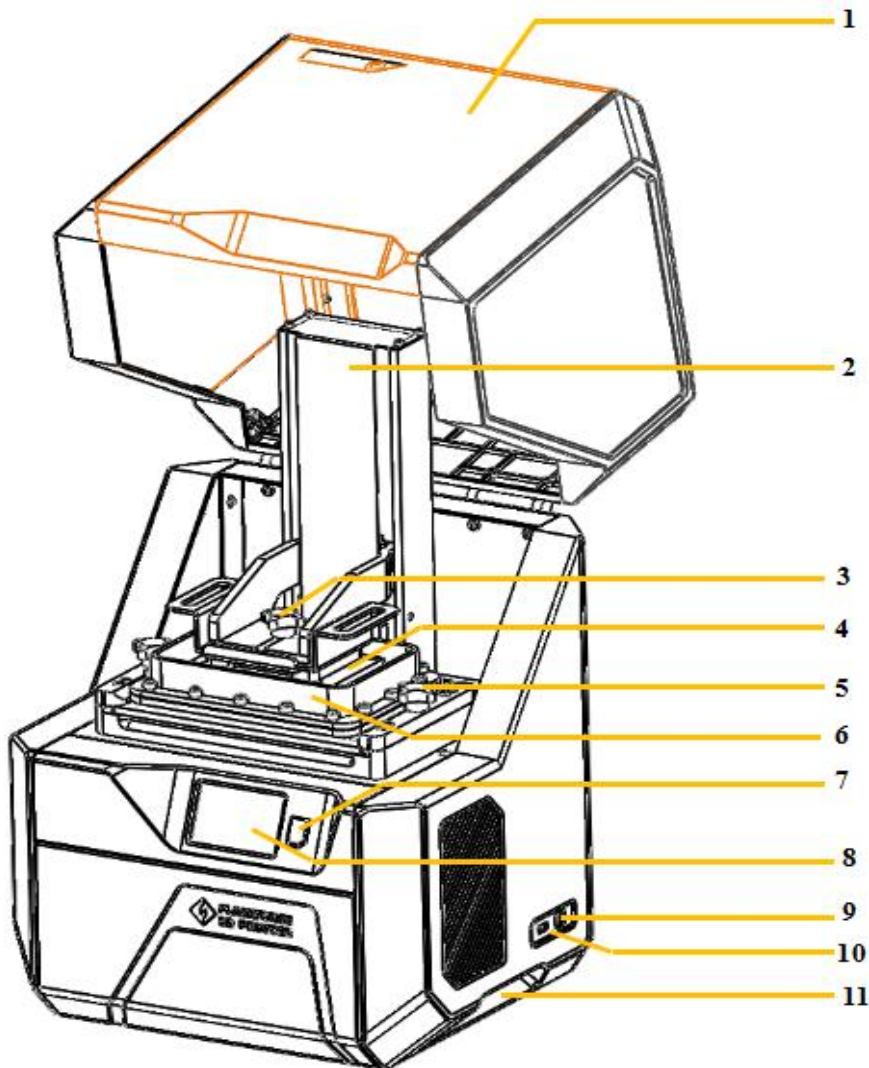

- | | |
|-------------------|------------------------|
| 1. Light Shield | 7. Touch Screen Button |
| 2. Z-Axis | 8. Touch Screen |
| 3. Platform Screw | 9. USB Cable Input |
| 4. Build Plate | 10. USB Stick Input |
| 5. Vat Film Screw | 11. Handle Slot |
| 6. Resin Vat | |

2.1.2 Accessory Box

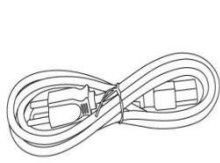

Power Cable



USB Cable



Quick Start Guide



After-sales Service Card

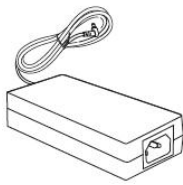

Power Adapter

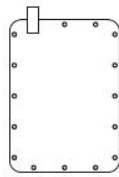

Vat film



Vinyl Gloves



Brush

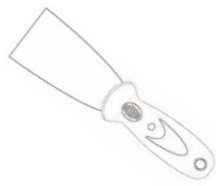

Metal Scraper

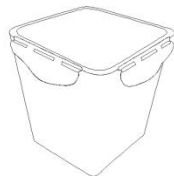

Rinse Bucket



Plastic Scraper



Soft Cloth



Photopolymer Resin
(500ml)



Accessories Kits



Spare Screw Kits

Accessories Kits Contents:

Hexagon Wrench (2.5mm*1/3mm*1/5mm*1), Phillips Screwdriver, USB Stick, Plastic Tweezers

Spare Screw Kits:

Hexagon Socket Head Cap Screws, Flat Washer, Spring Washer

2.1.3 Terms

Build Plate	The surface on which the Hunter builds an object.
Build Volume	The three dimensional amount of space that an object will use once it is completed. The largest build volume of Hunter is 230*150*140mm.
Resin Vat	Which is used to store photopolymer resin.
Z-Axis Set	The device that changes the direction of Z-axis, it can control the build plate up and down.
Light Shield	The open-close cover that used for dust proof and antiglare.
Light Engine	A device that used for projecting slicing file, which ensure stable performance for long term usage.

2.1.4 Reference

Name	Hunter
Print Technology	Digital Light Processing(DLP)
Screen	3.5" color IPS Touch Screen
Build Volume	120*67.5*150mm
Layer Resolution	0.25-0.05mm
Print Accuracy	±0.05mm
Positioning Accuracy	1920×1080 pixel
Material	Photopolymer Resin
Build Speed	10 mm/h
Software	FlashPrint
Support Formats	3MF/STL/OBJ/FPP/BMP/PNG/JPG/JPEG; GX/G
OS	Win xp/Vista/7/8/10、 Mac OS、 Linux
Product Dimensions	560*360*320mm
Net Weight	15Kg
AC Input	Input: 100V-240VAC, 47-63Hz Power: 65W
Connectivity	USB cable, USB stick, WiFi

Chapter 3. Unpacking

This chapter will present you the whole unpacking procedure of Hunter 3D printer. **(Note: Make sure you read the whole unpacking guide)**

1. (3-1) Put Hunter package on the clean, tidy workbench, using a knife to cut the tape from the bottom.



3-1

2. (3-2) Set the Hunter upright, lay the white foam on the floor and lift the carton.



3-2

3. (3-3) Remove the foam and accessory box from top. You will find a **Quick Start Guide**, an **After-Sales Service Card** and a **Spare Vat Film** inside.



3-3

4. (3-4) Accessory box contains USB cable, power cable, scraper, plastic scraper, brush, non-woven cloth, spare screw kits, plastic tweezers, hexagon wrench (2.5mm*1/3mm*1/4mm*1), Phillips screwdriver, USB stick.



3-4

5. (3-5) Tilt the Hunter to the left and remove the foam on the right. And vice versa remove the foam on the left.



3-5

6. (3-6) There is a carton box in each foam, on holds a 500ml bottle of photopolymer resin, another includes a power adapter.



3-6

7. (3-7) Remove the plastic bag, the seal is on the bottom.



3-7

8. (3-8) Remove the clear protection film.



3-8

9.(3-9) Open the cover and tear off the protection film as shown.



3-9

10. (3-10) Tear off the protection film on the foam.



3-10

11. (3-11) Hold the circled place with hands, then lift it up until the bottom foam is raised above the resin vat.

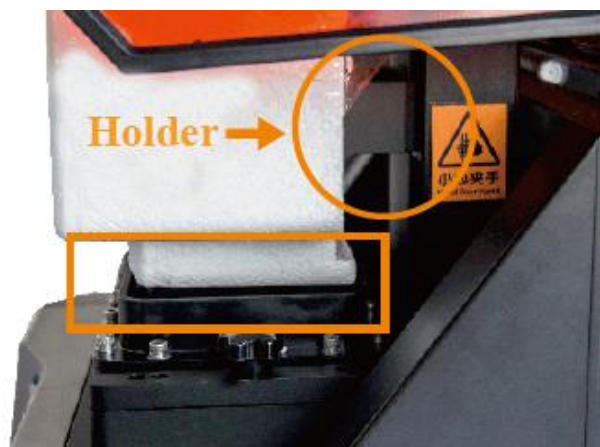

3-11

12. (3-12) Take out the foam block, there is a rinse bucket in the foam, which contains a pair of vinyl gloves.

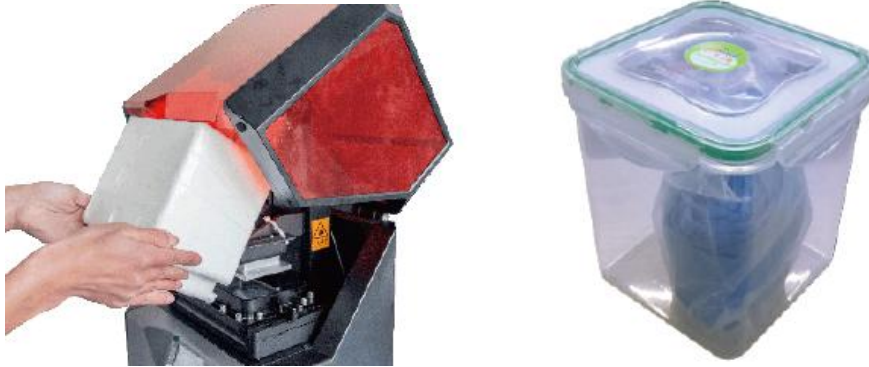

3-12

13. (3-13) Cut the white ties that hold the z-axis.

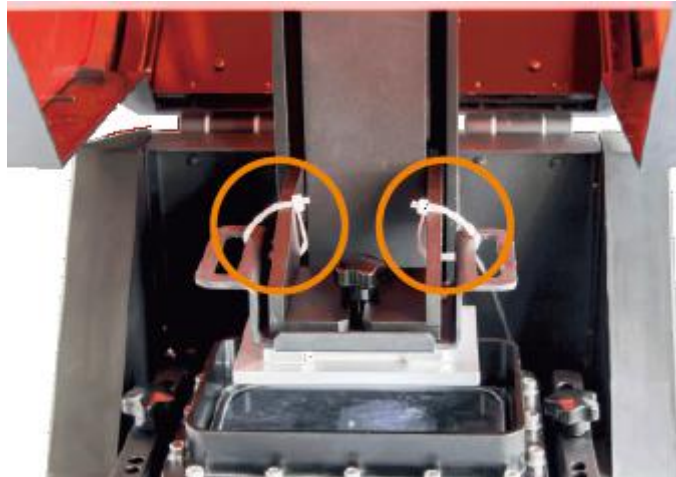

3-13

Now you have finished unpacking, you can see the complete Hunter 3D printer and accessories.

Chapter 4 . Hardware Assembly

The Hunter comes pre-assembled and is almost ready-to-print (ARP). All you need to do is to plug into the electronic power and pour the photopolymer resin. It will only take between 5 to 10 minutes before you can start up the Hunter and prepare for your first 3D print!

4.1 Pour Photopolymer Resin in to Vat

(4-1) There is a 100ml bottle of photopolymer resin in each Hunter. Tear off the seal open the cap, there is a rubber plug at the mouth of the bottle. Lift the ring open and take out the rubber plug. Please put on gloves during operation.



4-1

(4-2) Pour the photopolymer resin into resin vat slowly, fill it one-third full each time. Don't go over than the maximum scale mark. Be sure not to pour too fast to avoid spilling. Before pour the resin please make sure the vat dustless without fingerprints. Clean the vat with non-woven cloth if it is necessary.



4-3

4.2 Plug in Power Cable & turn on the Hunter

(4-4) Connect power cable and power adapter.



4-4

(4-5) Plug the power cable into the outlet on the back of Hunter and turn on the power switch.



4-5



4.3 Screen

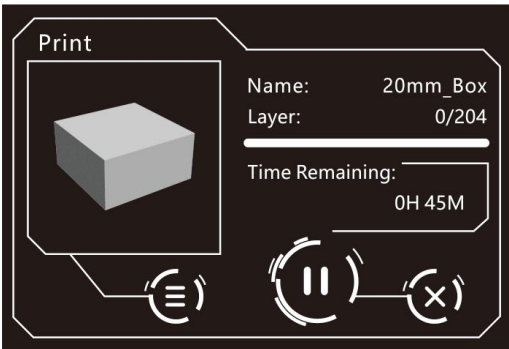
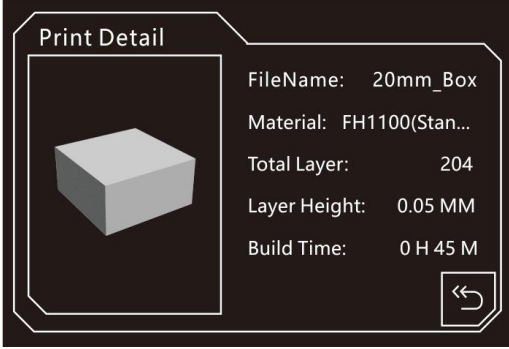

4.3.1 Print

	<p>Print: Enter into print interface; Settings: Enter into setting interface.</p>
	<p>Internal Memory; USB Memory.</p>
	<p>File List: It can preview models that stored in memory, tap the model to start printing; Page up; Page down; Delete model; Back.</p>
	<p>Model View: To show the 3D preview of the model, and it shows the file name, material, total layer, layer height and build time; Copy: To copy the files to the local memory card from the USB stick. Start: start to print this model; Back.</p>

	<p>Print:</p> <p>Printing information: To show 3D preview of the model, file name, layer and time remaining;</p> <p>Print Detail: To enter print detail interface;</p> <p>Pause/Resume printing: To pause/resume printing;</p> <p>Abort printing: To stop printing.</p>
	<p>Print detail:</p> <p>File name;</p> <p>Material: The printing material;</p> <p>Total layer: The total layer of the model;</p> <p>Layer height: The layer height of the model;</p> <p>Build time: The time of printing the model;</p> <p>Back.</p>

4.3.2 Setting

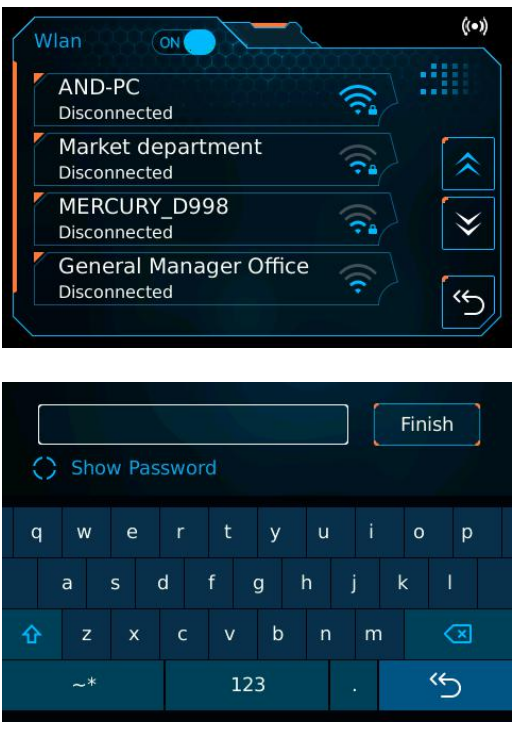
	<p>Settings:</p> <p>Printer Status: To show printer real-time status;</p> <p>WLAN: To turn on the WiFi;</p> <p>Hotspot: To turn on the hotspot;</p> <p>Z Move: To control the movement of Z-axis;</p> <p>Z Offset: To compensate the subtle movement of z-axis within $\pm 1\text{mm}$;</p> <p>Focusing: To adjust the focal distance;</p> <p>Language: To set the display language;</p> <p>Update: To update the firmware;</p> <p>About: Information about printer;</p> <p>Back.</p>
	<p>Printer Status:</p> <p>UV Shield: Open/Close;</p> <p>Temperature;</p> <p>Projector Hours: To show the hours that projector has worked;</p> <p>Back.</p>

	<p>Wlan:</p> <p>Wlan: To open or close the wlan;</p> <p>Wlan list: To select available WiFi signal;</p> <p>Password: To enter the password;</p> <p>Finish: To connect to the WiFi signal;</p> <p>Back.</p>
	<p>Hotspot:</p> <p>Hotspot: To open or close the hotspot;</p> <p>SSID: To enter the hotspot name;</p> <p>Password: To enter the hotspot password;</p> <p>Back.</p>
	<p>Z Move:</p> <p>Move up: To move the z-axis up;</p> <p>Move down: To move the z-axis down;</p> <p>Homing: Back to initial point;</p> <p>Zero: Back to zero point;</p> <p>Back.</p>



Z Offset:



After tapping [**Z Offset**], the prompt box will pop up. Make sure there is nothing below the build table, then tap [**Yes**] and wait for the build platform moving.

Move up: To move the z-axis up;

Move down: To move the z-axis down;

Back.

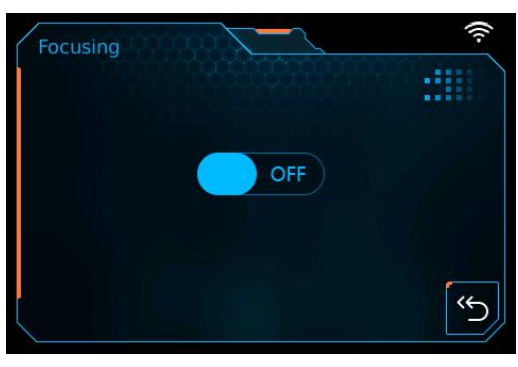
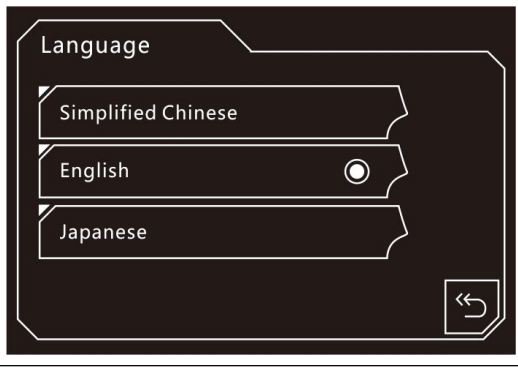
After tapping [**Back**], the printer will start homing.

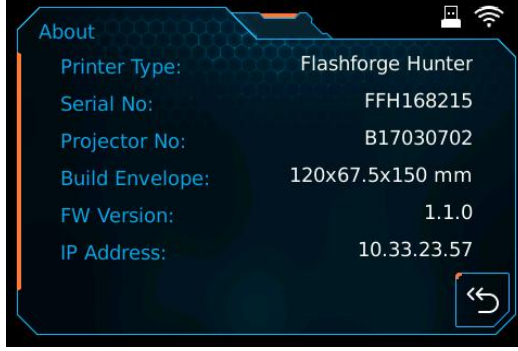
	<p>Focusing: ON/OFF: To open or close the focusing. It is not suggested do this operation by users. Please contact us before focusing.</p>
	<p>Language: To select the display language.</p>
	<p>Update: To show the update information, in network connection you will be promoted to update the firmware if there is available latest version.</p>
	<p>About: It displays the basic information about the device.</p>



Chapter 5: About Software

This chapter talks about the basic function of FlashPrint. For more information about advanced function, you can browse our website www.FlashForge.com.

5.1 Software Installation

5.1.1 Software Acquisition

Method 1: To get the installation package from the USB stick in the toolkit.

 FlashPrint_3.7.1_win64	2016/1/8 8:48	Windows Install...	41,637 KB
 FlashPrint_3.7.1_win32	2016/1/8 8:48	Windows Install...	37,995 KB
 FlashPrint_3.7.1_mac	2016/1/8 8:47	压缩(zipped)文件...	16,599 KB

Method 2: Open the link below to download the installation package:

<http://www.FlashForge.com>

Support---Downloads---FlashPrint---Choose the software version---Download

5.1.2 Software Installation and Start-up

1. Decompress the zipped file or start the installation program, and then install the software according to the direction.
2. Start the software with the start menu shortcut or by clicking the software icon.(See 6-1)



5-1

5.2 Exploring FlashPrint

5.2.1 Machine Type Selection

! After starting FlashPrint, you need to select the target machine type first.

When you start FlashPrint, a dialog box will pop up. Just need to select FlashForge Hunter in the machine type list and click **[OK]**. You can also change the machine type via clicking **[Print]**--**[Machine type]**. Please see graphic 5-2:

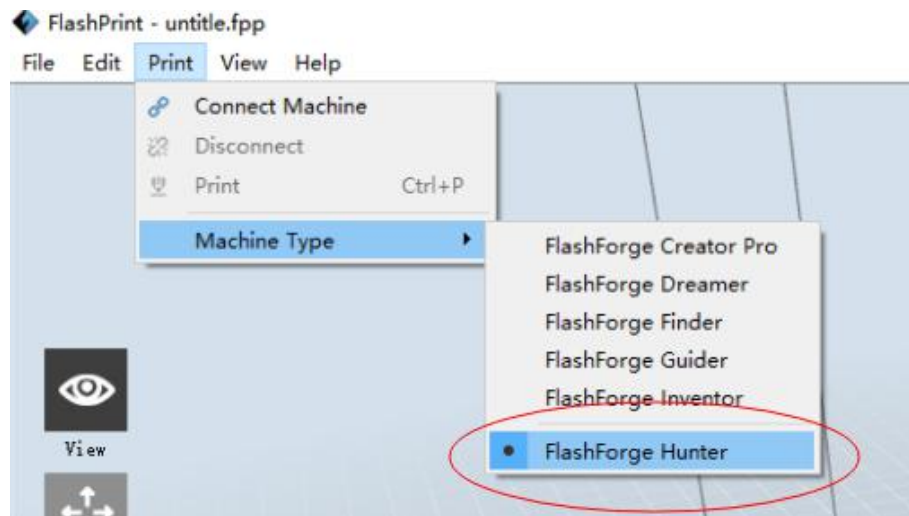





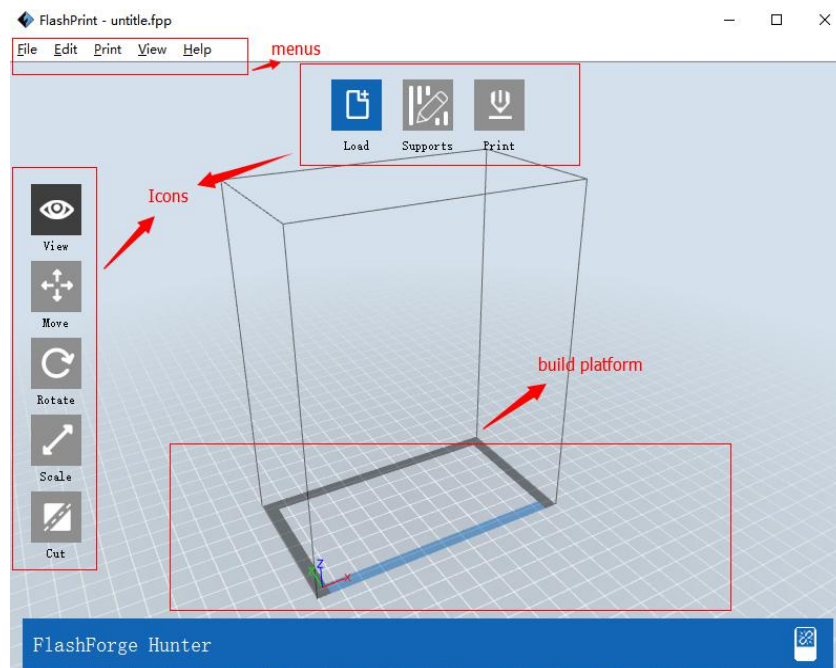



5-2

5.2.2 FlashPrint Menus



5-3

	Load files.
	Enter the support edit mode
	View FlashPrint home screen from one of six viewing angles.
	Move model around on XY-axis; shift+click to move along Z axis
	Turn and rotate your model
	Scaling the size of your object
	Cut the model into several parts
	Print it directly with your Hunter or export to your USB stick.

5.2.3 Loading

You can load a model file or Gcode file into your FlashPrint by the following six methods:

Method 1: Click the **Load** icon on the main interface. Then select the object file.

Method 2: Select the file for loading and drag the file to the main interface of the software.

Method 3: Click **[File]--[Load File]**. Then select the object file for loading.

Method 4: Click **[File]--[Examples]** to load the example files

Method 5: Click **[File]--[Recent Files]** to load the files opened recently.

Method 6: Select and drag the target file to the icon of FlashPrint.

Note: **.STL, .SLC, .OBJ, .3MF and .FPP**, ways to store 3D models, are supported by FlashPrint for editing.

Generating Rilievo

Load a png, jpg, jpeg, bmp picture file into the FlashPrint. And the following dialogue box (5-4) will pop up. The setting box includes settings for shape, mode, maximum thickness, base thickness, bottom thickness, width, height, top diameter and bottom diameter.

Shape: including plane, tube, canister and lamp.

Mode: including “darker is higher” and “lighter is higher”.

Maximum thickness: Z value of the model

Base thickness: The minimum raft thickness and the default value is 0.5mm

Width: X value of the model

Depth: Y value of the model

Bottom thickness: For tube, canister, lamp and seal to set up bottom thickness

Top diameter: For tube, canister, lamp and seal to set up the top diameter

Bottom diameter: For tube, canister, lamp and seal to set up the bottom diameter

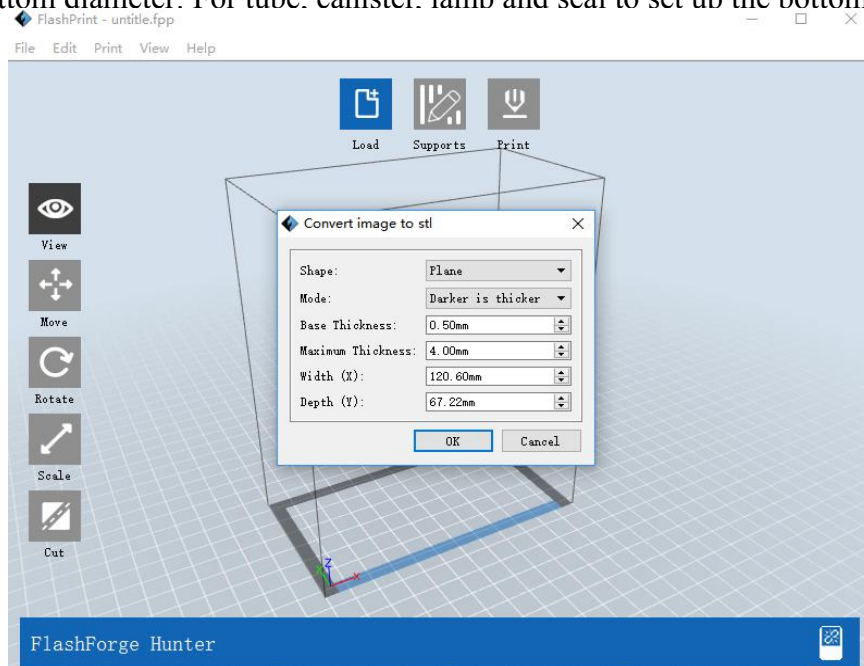

5-4



Plane 5-5

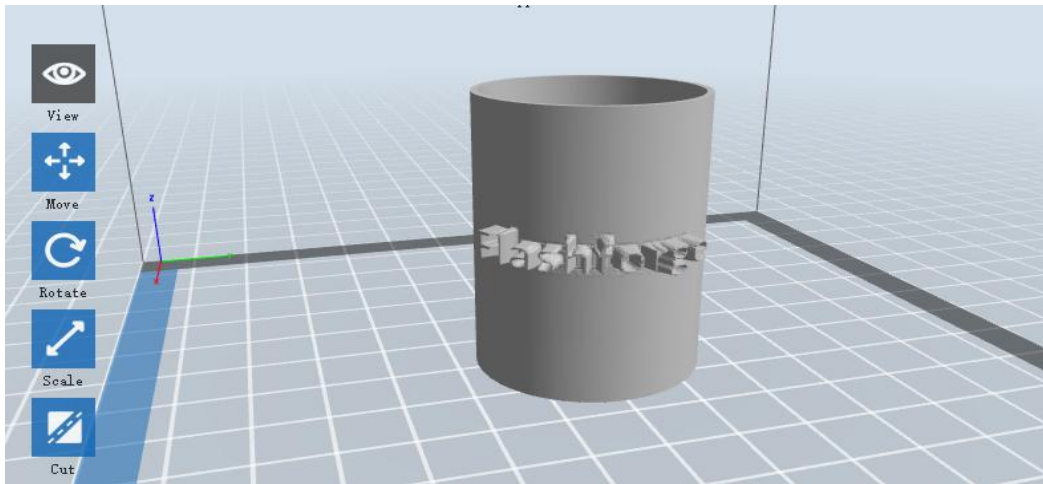

Tube 5-6

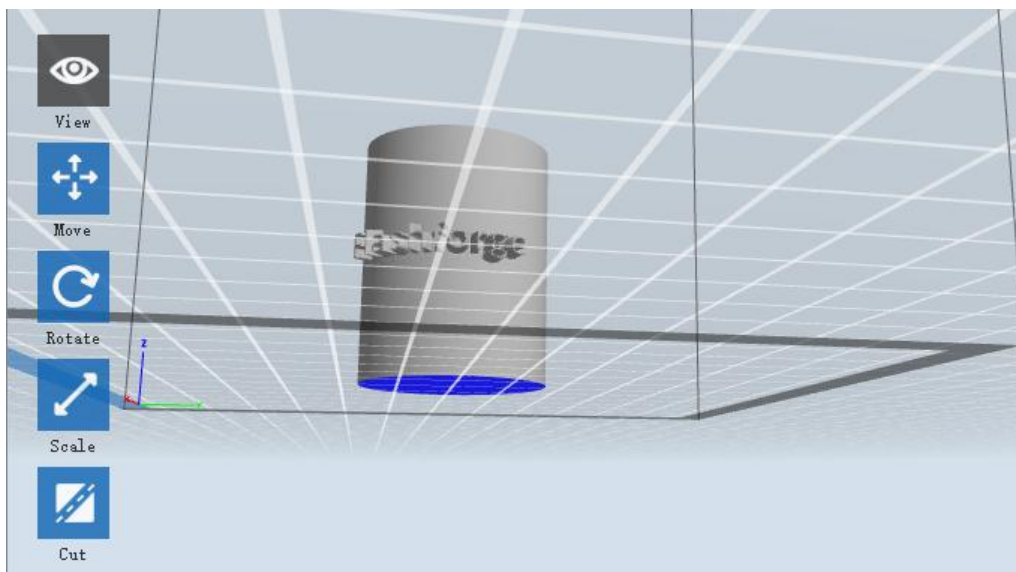

Canister 5-7

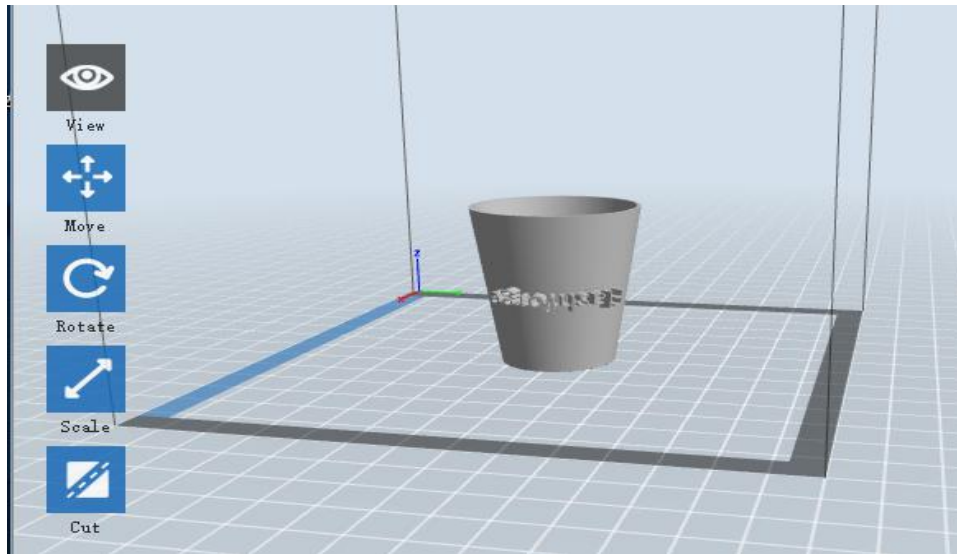

Lamp 5-8

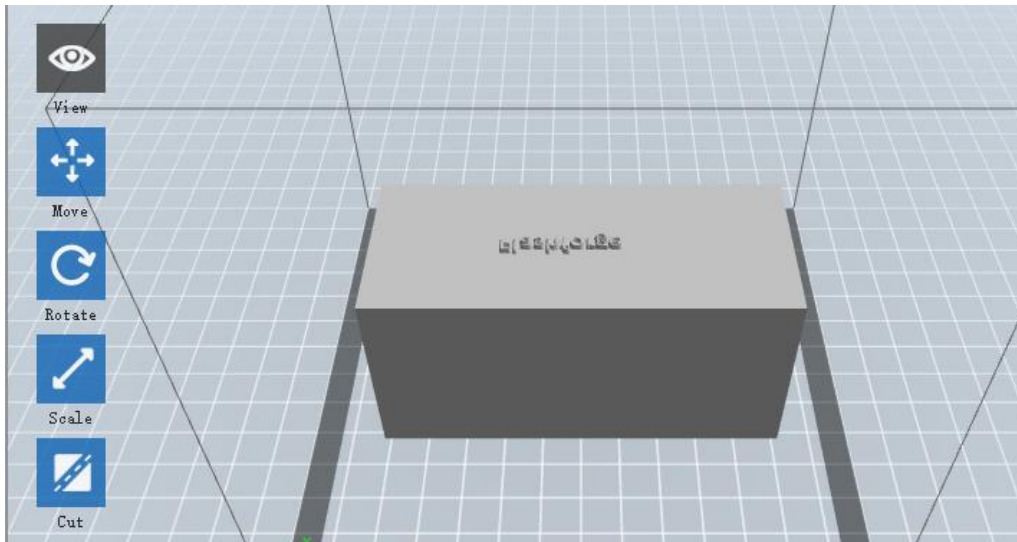

Seal 5-9

5.2.4 Views

① Changing views

Change model views by moving, rotating, scaling.

● Drag

Click the [\[View\]](#) icon and then you can move the object by the following three methods:

Method 1: Hold down the left mouse button and drag.

Method 2: Hold down the mouse wheel and scroll up and down.

Method 3: Hold down the Shift key, hold down the right mouse button and drag.

- **Rotate**

Click the **[View]** icon and then you can rotate the object by the following two methods:

Method 1. Hold down the right mouse button and drag.

Method 2. Hold down the **Shift** key, hold down the left mouse button and drag.

- **Scale**

Rotate the mouse wheel to enlarge or shrink the build plate.

② Set View

Allow users to view the object on the build plate. Six views are under the view menu, that is, bottom view, top view, front view, back view, left view and right view.

Method 1: Click the the **[View]** button, there are six views in the drop- down list

Method 2: Click the the **[Look]** icon on the left, click it again and a submenu will appear with six views for selecting.

③ Reset View

Allow users to reset views by the following two methods:

Method 1: Click the **[View]** menu and select **[Home View]**

Method 2: Click the **[View]** button on the left, click it again and you will see the viewing options, you can click **[Reset]**.

④ Show Model Outline

Click **[View]**--**[Show Model Outline]**, it will highlight the yellow border of the object

⑤ Show Steep Overhang

Click **[View]**--**[Show Steep Overhang]**. When the intersection angle between the model surface and horizontal line is within the overhang threshold value, the surface has steep overhang and it becomes red in the software. Overhang threshold value could be set as needed. The default value is 45 degree.

5.2.5 Move

Select the object and move the object by the following two methods:

Method 1: Click the **[Move]** icon on the left. Long press the left mouse button and drag to adjust the location of the model in XY direction. Long press the **Shift** key and the left mouse button, drag to adjust the location of the model in Z direction. The distance and the direction of the movement shall be displayed.

Method 2: Click the **[Move]** button on the left and then enter the distance value. Click **[Reset]** to reset distance values.

Note: Users shall click **[Center]** and **[On Platform]** after the location adjustment to ensure the model(s) be within the build area and on the build platform. If a specified position is needed, only click **[On Platform]**.

5.2.6 Rotate

Select the target object and rotate the object by the following two methods:

Method 1: Click the **[Rotate]** icon on the left and three mutually perpendicular rings appear around the object. Click one ring and rotate on the present axis, you will see the rotation angle and direction in the center of circle. In this way, you could make the model rotate on X/Y/Z axis.

Method 2: Click the **[Rotate]** icon on the left, and then enter into rotating angel values in X/Y/Z axes positioning. Click **[Reset]** to reset rotating angel values.

5.2.7 Scale

Select the target object and scale the object by the following two methods:

Method 1: Click the **[Scale]** icon on the left, hold down the left mouse button and scale the model. The corresponding values will display near the object.

Method 2: Click the **[Scale]** icon on the left and then enter into scale values in X/Y/Z axes positioning. Click the **[Maximum]** button to get largest size possible for building. Click **[Reset]** to reset the size of model.

Note: If the **[Uniform Scaling]** radio button is clicked, it will scale the model in equal proportion when changing **value** in any positioning of the model. Otherwise it will only change the value of the corresponding positioning.

5.2.8 Cut

Left-click on the model to select it and double-click on the **[Cut]** icon to set the cut plane. The direction and position are available for setting.

① Draw with Mouse

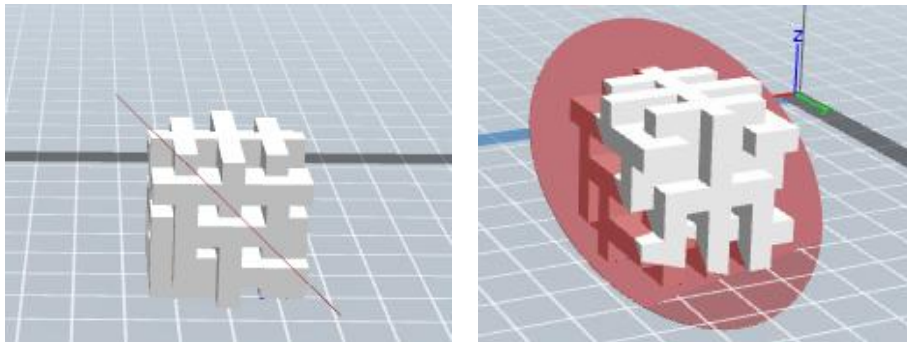

② X Plane

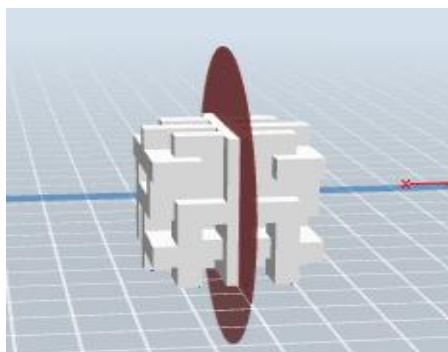

③ Y Plane

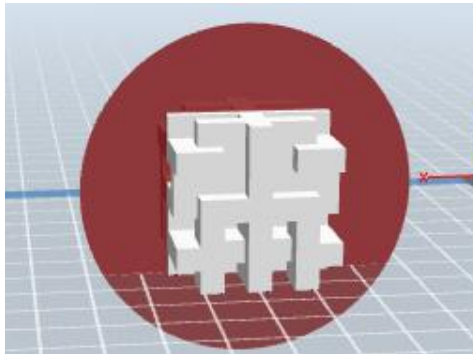

④ Z Plane

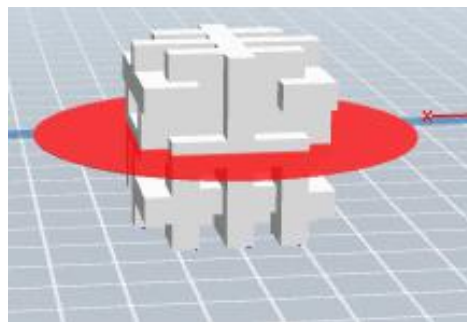

5.2.9 Supports

After loading the model, click **[Edit]--[Supports]** or click the **Supports** icon directly, then you will enter the support edit mode (5-10). Click **[Back]** to exit when you finish editing.

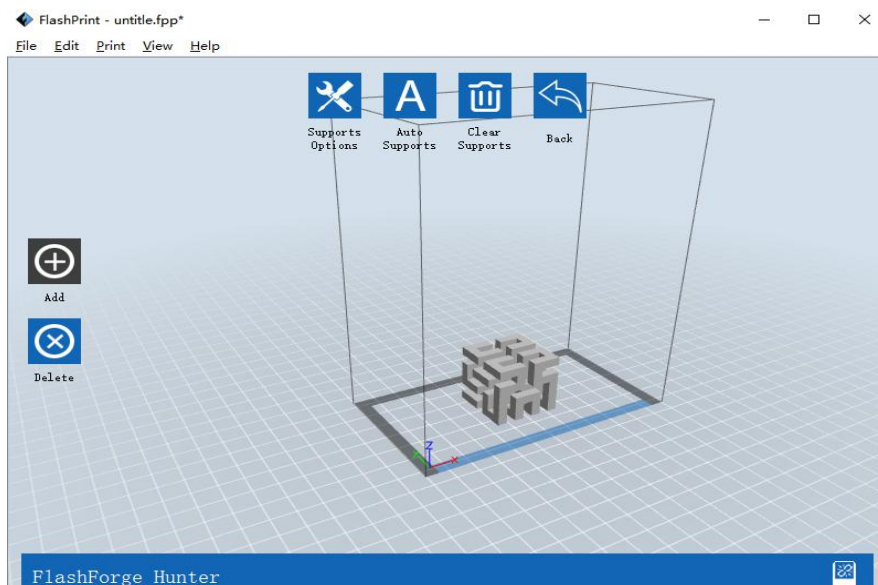

5-10

①Support Options

Click the Support Options, an option box will appear, supports options only include “Columnar”.

Overhang Thresh: The parameters used to judge whether the model surface need to generate the supports. The higher the value is , the less the supports are. The value is between 30° to 60° .

Tip Diameter: The diameter size of support and model contact parts, the bigger diameter the stronger support, and harder to remove. The value is between 0.25mm to 1mm.

Post Diameter: The diameter of support post, the larger the diameter of supporting the stronger it will be, the more difficult to spin off. The value is between 0.25mm to 2mm.

Base Diameter: The diameter of the bottom post, the larger the base diameter the easier supports stick to the built plate, the more difficult to spin off. The value is between 0.2mm to 3mm.

Base Height: The height of the support at the bottom of the bold part, the higher the base height, the stronger support bottom, the more difficult to spin off. The value is between 0 to 5mm.

Post Space: The spacing among posts, the smaller the value the closer the posts. The value is between 1mm to 10mm.

Exterior Only:

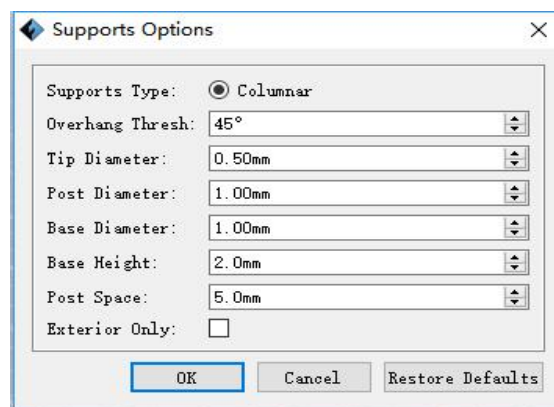

② Auto Supports

Click the **[Auto Supports]** button, the software will judge the position where supports are needed and generate corresponding treelike or linear supports. If it is a model with supports, the existing supports will be deleted and new supports will be generated.

③ Add Supports

Supports will be added once clicking the **[Add]** button. Move the cursor to the position where supports needed, left-click to choose the starting point of supports, hold down the left mouse button and drag the mouse the supports preview will show up (if support surface doesn't need support or the support column angle is too large, will highlight the support review).Loosen the left mouse button, if support column doesn't meet with model, then support will be generated on origin and terminal point (the highlighted preview support won't generate support structure)

④ Clear Supports

Click **[Clear Supports]**, all supports will be deleted. The operation can be repealed via clicking **[Undo]** or pressing the shortcut key **Ctrl+Z**.

⑤ Delete Supports

Supports will be deleted once clicking the **[Delete]** button. Move the cursor to the supports needed deleting, current supports and its subnode support will be highlighted, click the left mouse button to delete these highlighted support.

5.2.10 Print

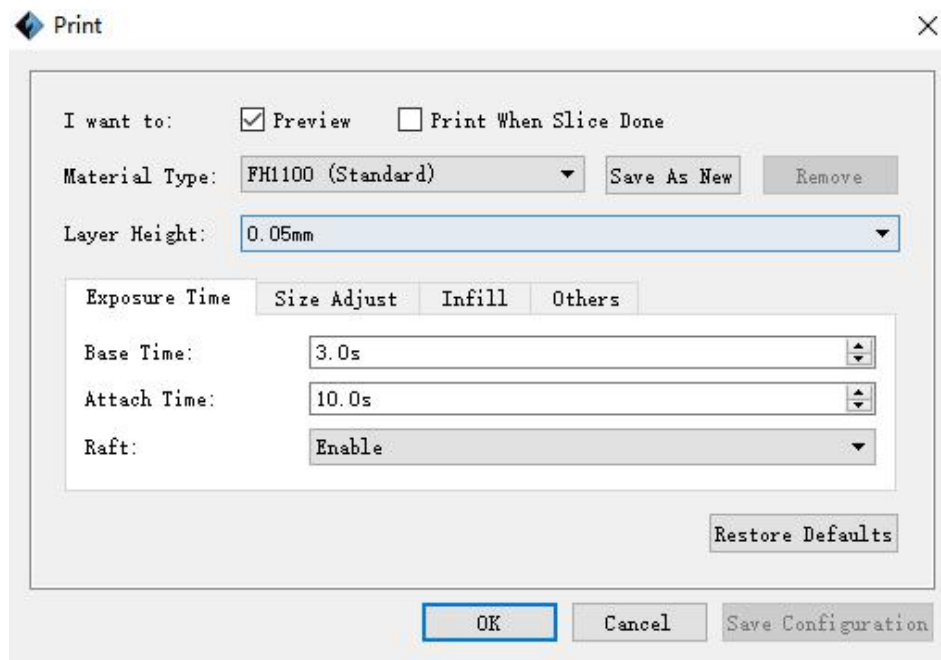

5-12

- ① **Preview:** Choose to enter preview interface or not
- ② **Print when slice done:** Print or not when slice done
- ③ **Material type:** Choose according to the type of model
- ④ **Save as new:** To custom the material type and remember this choice.
- ⑤ **Remove:** Clear the custom material type.
- ⑥ **Layer height:** To set the height of each layer while printing, the default value is 0.025mm, optional values are 0.05mm. Higher the value is, lower printing precision and higher speed the model has, and vice versa.
 - **Expose time**
 - a. **Base time:** To set expose time to solidify a layer of photopolymer resin.
 - b. **Attach time:** To set the expose time that solidify the attached a layer of photopolymer resin.
 - c. **Raft:** To choose whether print the raft.
 - **Size adjust**

- a. **X adjust:** According to the previous printing error to adjust the x-axis size.
- b. **Y adjust:** According to the previous printing error to adjust the x-axis size.

- **Infill**

- a. **Fill Density:** Fill rate.
- b. **Shell Thickness:** To set the shell thickness value between 1mm to 10mm.
- c. **Infill Thickness:** To set the infill thickness value between 0.5mm to 5mm.

- **Others**

- a. **Light intensity:** According to the sensitivity of light to adjust the light intensity. Use FlashForge photopolymer resin need not any adjustment, default 100%.

5.2.11 File Menus

① New Project

Click **[File]--[New Project]** can build a blank project. If there is an unsaved modification on previous project, then it will inform you whether the modification needs to be saved or not. Click **[Yes]** will save the modification, while click **[No]** will abandon it. If click **[Cancel]** or close tool tip, then it will cancel the new project.

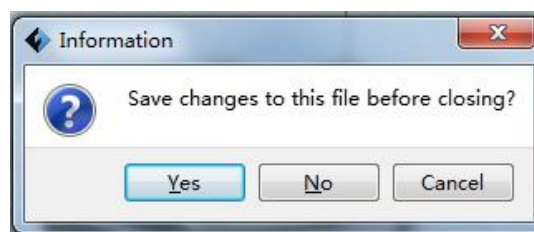

5-13

② Saving

After finishing the model edit and adjustment, there are two ways below to save all models in the scene.

Method 1:

Click **[File]--[Save Project]** in the menu bar to save the file as a project file with the “.fpp” suffix, all models in the scene (include support) are independent. After reloading the files, extruder configuration information and model position will be the same as the configuration during saving.

Method 2:

Click on **[File]--[Save as...]** to save the model as project file .fpp or .stl and .obj. For .stl and .obj, models are integrated as one (include support part). If load it again, only the position of the model was saved, not included the printing parameters.

③ Preferences

Click **[File]--[Preferences]**, you can choose language and if needs detecting update when start

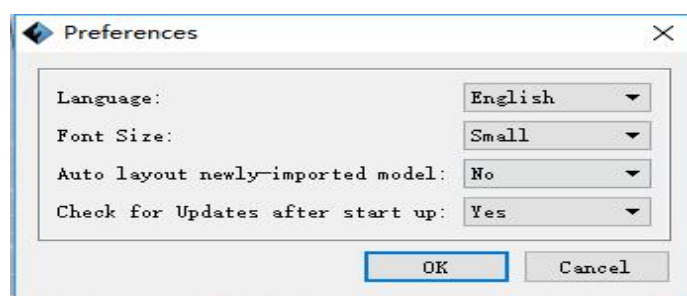

5-14

- **Language:** The software supports several languages, namely, Chinese (simplified Chinese and traditional Chinese), English, French, Korean, Japanese and so on.
- **Font Size:** Set the font size.
- **Auto layout newly-imported model:** Set Yes or No.
- **Check for Update after start up:** It is used to preset if it is necessary to activate the online automatic update function, if choose yes, every time when you open software, it can online detect if it is a new version software, once new version found, it will reminds users to download and install new version firmware.

5.2.12 Edit Menus

① Undo

Allows users to undo the recent edits by the following two methods:

Method 1: Click [\[Edit\]](#)--[\[Undo\]](#).

Method 2: Press the shortcut [Ctrl+Z](#).

② Redo

Allows users to redo the most recent edit you have undone to your model file by the following two methods

Method 1: Click [\[Edit\]](#)--[\[Redo\]](#)

Method 2: Press the shortcut [Ctrl+Y](#).

③ Empty Undo-stack

To clean up the recorded operating steps so as to release the memory.

④ Select All

By the following two methods, you could select all models in the scene.(When models are too small to be seen or out of viewing scope, please click [\[Center\]](#) and [\[Scale\]](#) buttons to adjust the model.)

Method 1: Click [\[Edit\]](#)--[\[Select All\]](#).

Method 2: Press the shortcut [Ctrl+A](#).

⑤ Duplicate

Select the object and duplicate the object through the following two methods:

Method 1: Click [\[Edit\]](#)--[\[Duplicate\]](#)

Method 2: Press the shortcut [Ctrl+D](#)

⑥ Delete

Select the object and delete the object through the following two methods:

Method 1: Click [\[Edit\]](#)--[\[Delete\]](#)

Method 2: Press the shortcut [Delete](#)

⑦ Auto Layout All

Click **[Edit]**--**[Auto Layout All]** after loading one or more than one models, all models will be placed automatically as automatic placement rule.

⑧ Repair Models

Click **[Edit]**--**[Repair Models]** to repair models.

⑨ Supports

Click **[Edit]**--**[Supports]** to enter supports setting interface.

5.2.13 Print Menus

① Connect Machine

You can connect the Hunter with your PC via a USB cable or WiFi.

Note: The machine icon on the bottom right displays the connection status:

Connected



Disconnected



Method 1: Connect Via USB Cable

- a. Connect your Hunter with your PC via an USB cable.
- b. Turn on your Hunter and start FlashPrint.
- c. Click **[Print]**--**[Connect Machine]**, then select USB in the **[Connection Mode]** option and select machine you want to connect in **[Select Machine]** option. If you can not find your machine, click the **[Rescan]** button to scan your machine and select it. Finally click **[Connect]** button to connect to the printer. If you still can not find your machine after rescan, it means you haven't installed the driver in the software.

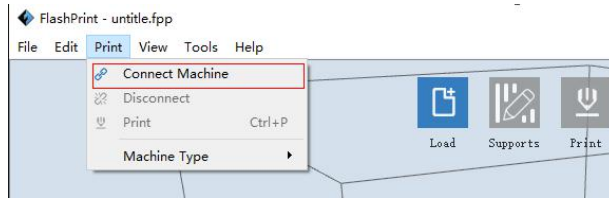

5-16

Method 2: Connect Via WiFi

1. Turn on Hunter.
2. Turn on Wi-Fi on the Hunter. Tap **[Tools]-[Setting]-[WiFi]-[WiFi ON]**.
3. Connect Hunter with an available WiFi signal, which is also connected by your computer.
4. Click **[Print]-[Connect Machine]**, it will top up box, then select Wi-Fi in the Connect mode. Type in **“192.168.0.102”** and **8899** in IP address, click **[Connect]**.

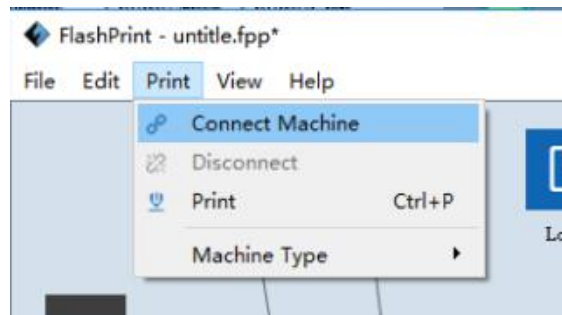

5-17

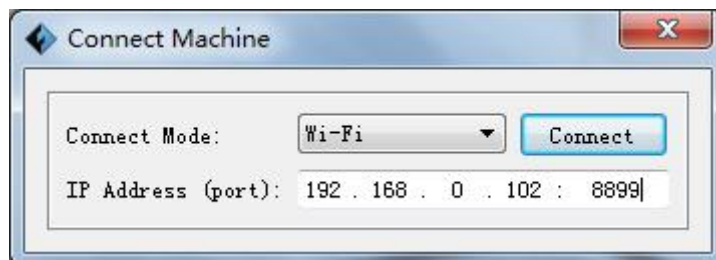

5-18

② Disconnect Hunter

Click **[Print]--[Disconnect]** to disconnect your PC and Hunter.

5.2.14 Tool Menus

① Update Firmware

Every time when you start FlashPrint, it will automatically detect and download the up-to-date firmware. If any update is available, a dialog box will pop up for reminding the users to update.

Step 1: Click **[Tools]--[Update firmware]**. It needs to cut off connection before updating firmware. If software and printer are already in connection, it reminds you cutting off the connection, and then choose **[Yes]** and go on to the next step.

Step 2: Choose corresponding printer type and firmware version and click **[OK]** in the firmware updating box. After confirming the printer is in free state, the software will automatically update the firmware.

Step 3: Reboot you Hunter and wait for 4-5 seconds, then you can see the update process bar. When the update finishes, it will go back to the main interface.

Step 4: Tap **[Tools]--[About]** to check whether the updated version is right.

③ On Board Preferences

When the computer and printer are in connection, click **[Tools]--[On Board Preferences]**, you can check the printer name.

④ Machine information

When the computer and printer are in connection state, click **[Tools]--[Machine information]**, you can check the machine type, machine name and firmware etc.

5.2.15 Help Menus

① First Run Wizard

② **Help Contents:** Click [\[Help\]--\[Help Contents\]](#), you can read the help contents.

③ **Check for Updates :** Click [\[Help\]--\[Check for Update\]](#) to detect the available updates online.

④ **About FlashPrint:** Click [\[Help\]--\[About FlashPrint\]](#), the software information box will pop up. The contents include the current software version and copyright information.

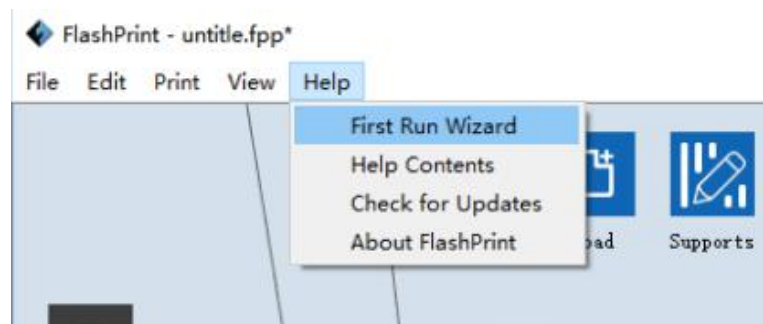

5-19

Chapter 6: Printing

This chapter will provide a step-by-step guide on turning a 3D model into a physical reality.

6.1 Generate Gcode File

Double-click **[FlashPrint]** icon to open FlashPrint software.



6-1

(6-2) Click **[Print]-[Machine Type]** and select **FlashForge Hunter**

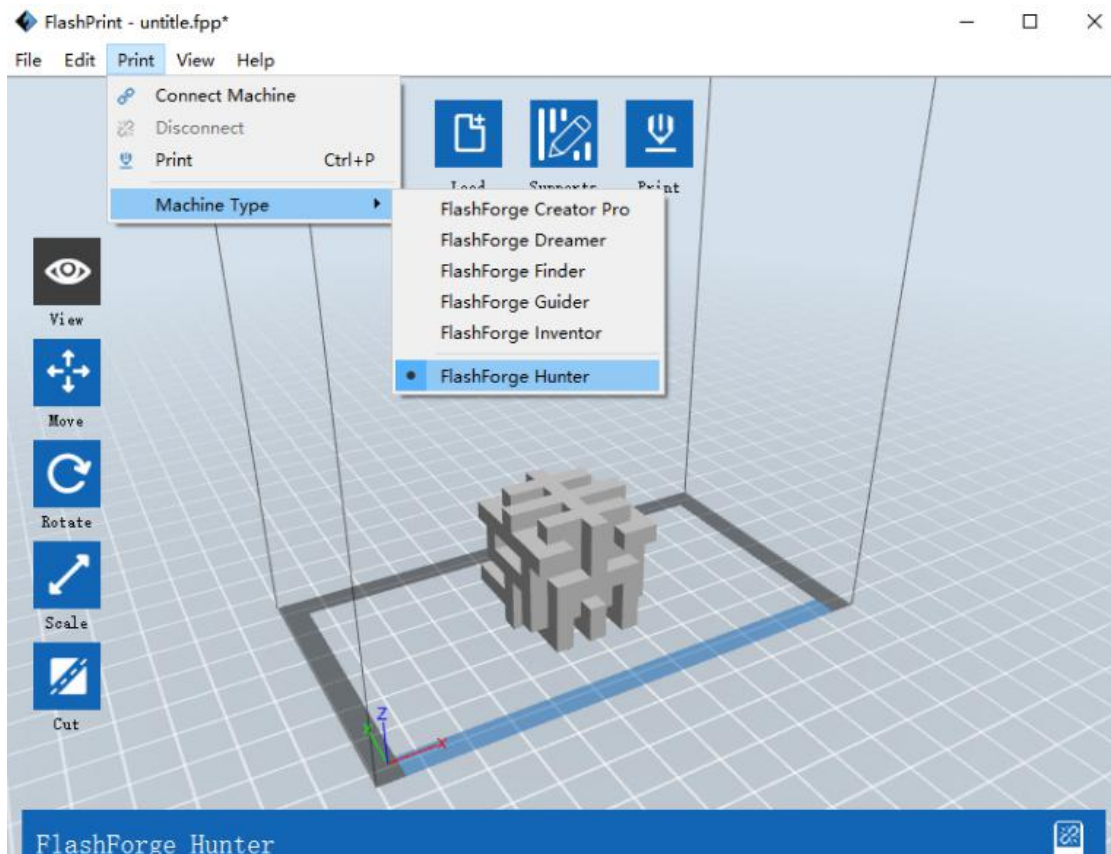

6-2

(6-3) Click **[Load]** icon, select .stl 3D files shown as follow:

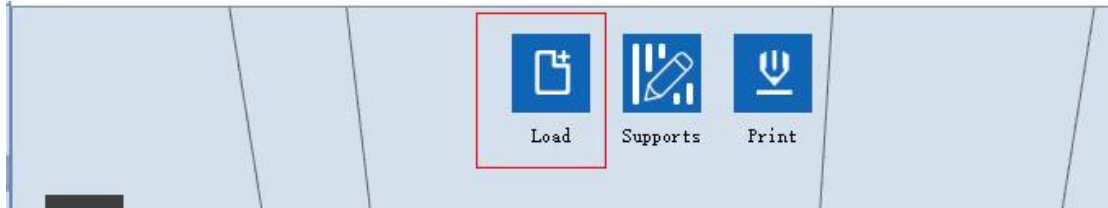

6-3

(6-4) Click **[Edit]-[Surface to platform]**, select on surface to contact the model and double click. After finished click **[back]** button, double click **[Move]** icon, then click **[on platform]-[Center]** icon.

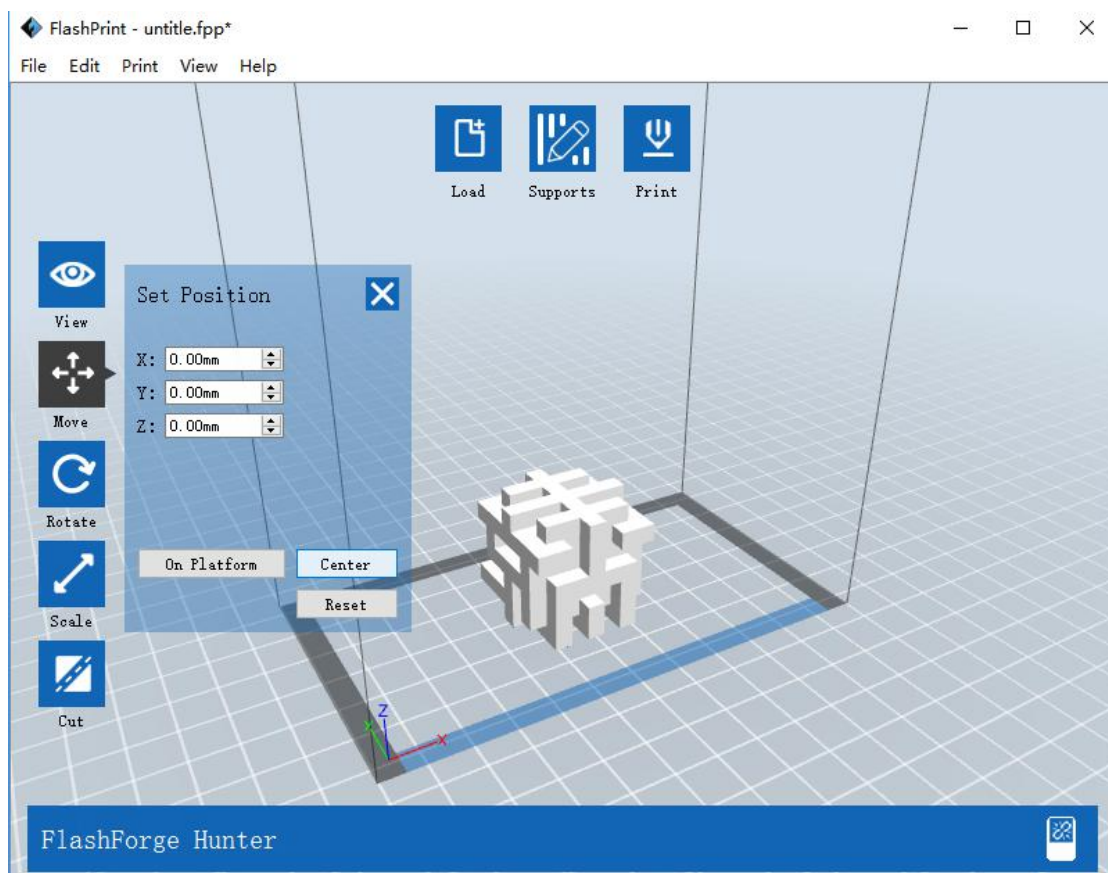

6-4

Note: If the model is in the right position, there is no need to do this step.

(6-5) Click **[Print]** icon to set the printing parameters. The default parameters is

shown below.

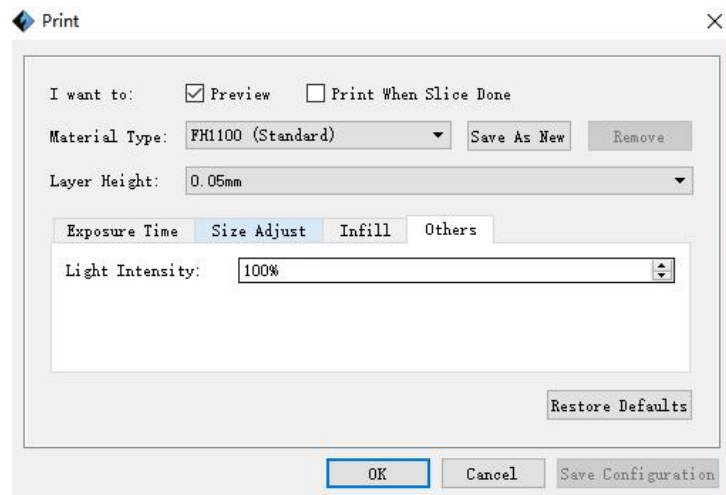

6-5

6.2 Methods of printing

Printing from USB

1. Connect Hunter to the computer with the USB cable.
2. Turn on the Hunter.
3. Select **[Print]** from menu bar, then select **[Connect]**.
4. Click on **[Rescan]**, then **[Connect]**.
5. Now the printer is connected with FlashPrint.
6. Click **[Print]** icon, and a printing options screen will appear.
7. Save the file at any location, and the object will start slicing.
8. After slicing the object, it will automatically upload the gcode to the Hunter.

Printing from USB stick

1. Click **[Print]**, and a printing options screen will show up.
3. Click **[OK]**, and save the gcode file in the USB stick.
4. FlashPrint will begin slicing the 3D model.
5. After slicing the object, take the USB stick from the computer. Insert it into the USB stick slot on the Hunter.

6. Tap **[Print]** and then tap the middle **USB stick** icon.
7. A list of file(s) will show up, press the file that you would like to print, then tap **[Yes]**.
8. The printer will now enter preheating phase and will start printing once it finishes preheating

Printing via Wi-Fi

After the printer and computer have connected WiFi (Please refer to 5.2.13), load the Gecod file in FlashPrint, then tap **[Print]** icon to start printing.

Notice: Please close the cover while printing.

6.3 Model Processing

(6-6)After finish printing, please put on vinyl gloves and open the light shield, hold the build plate and unscrew the platform screw, take out the build plate from horizontal direction carefully.

Attention: Please put on vinyl gloves during operation,

Carefully pour the used photopolymer resin into a clean bottle, it can be recycled.

Photopolymer resin needs to be stored in a dark, dry and cool place.

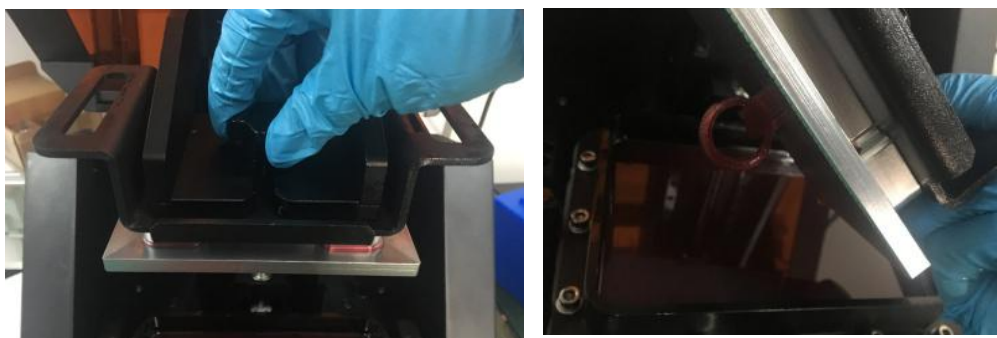

6-6

(6-7) Pour the absolute alcohol into rinse bucket halfway, immerse the build plate and model into rinse bucket and rinse it with brush.

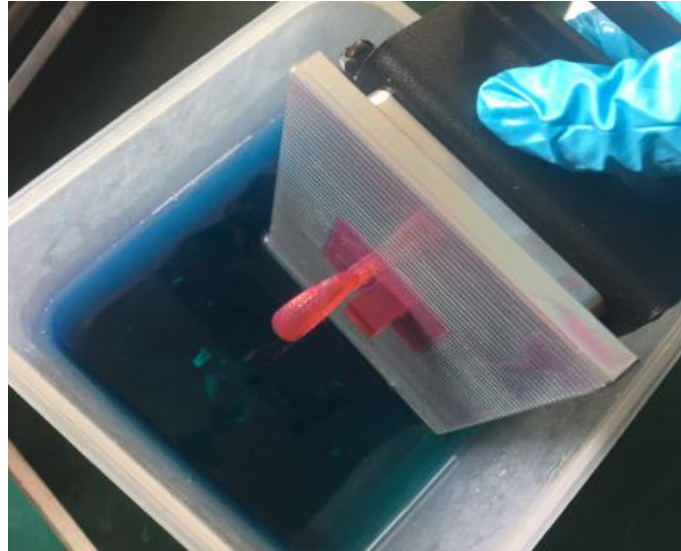

6-7

After finished washing, put the platform on the workbench and remove the model with metal scraper, shown as follow.

Attention: As the sharp metal scraper, please remove the model with care.

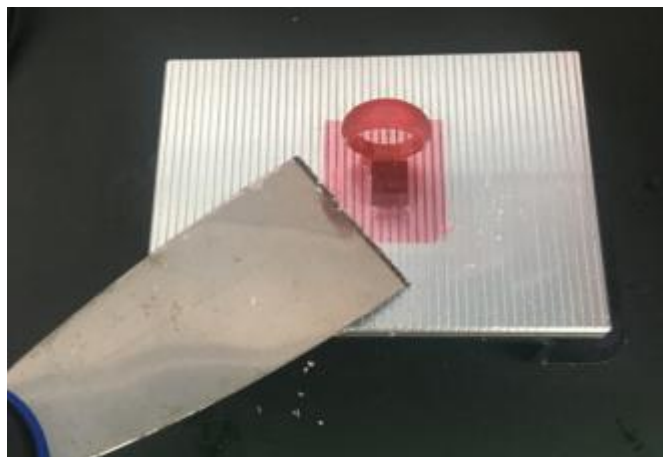

6-8

Notice: Do not pour the used resin back to the photopolymer resin bottle.

Do not pour the used resin into domestic sewage.

Chapter 7: Supports and Service

FlashForge team is on standby and ready to help you overcome any challenges you may have with your Hunter. If the issues or questions are not covered in this User Guide, you can seek for solutions on our official website or contact us via telephone.

There are solutions and instructions to common issues that can be found in our knowledge base. Have a look first as most basic questions are answered there.

<http://www.FlashForge.com>

The FlashForge support team can be reached by e-mail or phone between the hours of 8:00 a.m. to 5:00 p.m. PST Monday through Saturday. In case you contact us during off-duty time, your inquiry will be answered the following business day.

Tel: **400-699-1063**

QQ: [2850862986](https://www.qq.com) [2850863000](https://www.qq.com) [2853382161](https://www.qq.com)

Email: support@ff3dp.com

ADD: **No. 518, Xianyuan Road, Jinhua, Zhejiang**

***When contacting support, please have your serial number ready.**

The serial number is a bar code on the back of your Hunter

